

Rhino® Whole House Water Filtration

Model #EQ-300 High Capacity Filtration System



300,000 gal.
Certified
Capacity



Drink, shower, bath & live in
healthy water!

With the **Rhino®** Whole House Water Filtration System, you can enjoy bottled water quality throughout your entire home, in your showers, sinks, bathtubs, washing machines, and dishwashers, all for about 55¢ a day!

The Rhino® Central Filtration System is designed to be virtually maintenance free for 3 full years. No costly service calls or agreements, just replace the main filter unit once every 3 years, cost \$679.00, for great tasting healthy water on tap... always!

Effectively filters out chlorine, bad taste and odors from from municipally treated tap water as it enters your home. This patented multistage filtration process directs water through 4 stages of filtration for optimum performance.

Each system comes complete with an installation kit, ball valve and pre-filter for easy service and to prevent sediment from entering the filter system.

This deluxe, high-capacity unit should be installed by a licensed plumber to insure proper installation. Normal installation is 1-2 hours.

***The most valuable home appliance you can own!
Factory Direct Price \$1095.00***



Common Questions

Q: How long does the EQ-300 Whole House System last?

A: The EQ-300 unit was certified for a 300,000 gallon capacity at 8 gpm, the highest certified capacity of any whole house filtration system! The main filter section should be replaced every 3 years and the sediment pre-filter as needed, every 3-6 months. (package of 4 costs \$19.95)

Q: What are the benefits of whole house filtration?

A: By filtering all the water that enters your home, you not only greatly enhance the healthfulness of your household water, but you also dramatically improve your indoor air quality. According to the U.S. E.P.A., **“Every home in America has an elevated level of chloroform gas present due to the vaporization of chlorine... from tap and shower water.”**

Chlorine vapors are a suspected cause and irritant of respiratory problems such as Asthma, bronchitis and allergies. Filtered water will benefit every aspect of your family’s health.

This is the most valuable and beneficial home appliance you can own!

Q: How does the EQ-300 Whole House System work?

A: There are 4 stages. Please see the diagram below.

Stage 3

Contains a large granule bituminous activated carbon for improved filtration. This media is recognized by the U.S. E.P.A. as the “Best available technology for the water filtration.

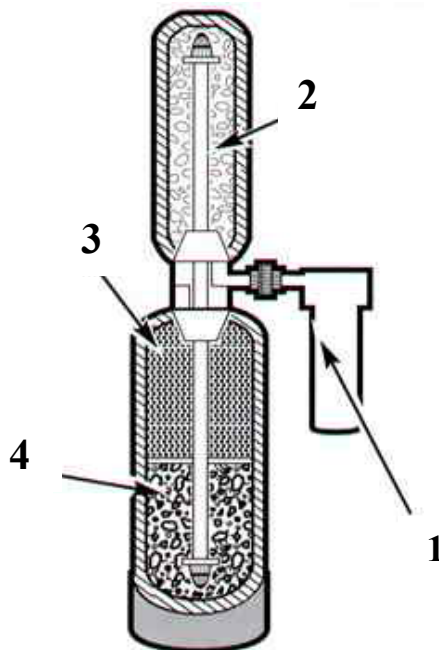

Stage 2

A natural media made of zinc and copper where granules are fused together by the process of water atomization. This combination creates an active filtration method, possessing a characteristic known as *redox potential*, which can alter the molecular structure of chlorine and turning it into a harmless zinc chloride.

Stage 4

Contains a small granule coconut shell based activated carbon for an expanded surface area, which provides the highest reaction kinetics, and absorptive capacity.



Stage 1

The sediment pre-filter uses a replaceable cartridge that mechanically filters down to five microns. This important first stage filters the sediment that may be in the water supply so that it doesn't clog the main filter and reduce water flow and/or filter life.

The EQ-300 is UPS shippable and weighs 65 lbs.

This product is warranted to be free from defects in materials and workmanship for one full year!

Contact;



325 N. Beach St.

Fort Worth, Texas 76111

E-mail info@aquasana.com

Order online at Aquasana.com or call toll free 866-2Drink8